

FEATURES

- Laser welded diaphragm
- Full welded construction
- Zero-leak path design

APPLICATION

- Oil & Gas applications
- Corrosive environments

REFERENCE

EN 837-3

Flanged



STANDARD PARAMETERS

Accuracy	:	CL 1.6
Ambient temperature	:	-40...+65°C (without dampening liquid)
	:	-20...+65°C (with dampening liquid)
Service temperature	:	10...150°C max.
Pressure limits	:	Steady pressure up to FS value
Weld joints	:	TIG argon arc welding

MATERIAL OF CONSTRUCTION

Sensing element	:	Diaphragm
Case & Ring material	:	AISI 304 SS (Bayonet type)
Diaphragm, Bourdon tube & Shank	:	AISI 316L SS (Shank welded directly to case)
Movement mechanism	:	AISI 304 SS
Seal body	:	AISI 316 SS
Dial	:	Aluminum, black graduation on white background
Pointer	:	Micro-zero adjustable, aluminum, black powder coated
Gaskets & filling plug	:	Neoprene
Window	:	Shatterproof safety glass

STANDARD SPECIFICATIONS

Dial size	:	DN100 / DN150
Range	:	-1...400 bar
Mounting pattern	:	Direct, Bottom connection
Process connection	:	1½" RF 150# as per ANSI B16.5
Seal filling fluid	:	Silicon DC 200
Ingress protection	:	IP 65
Execution	:	Dry

STANDARD SPECIFICATIONS : DAMPENING LIQUID FILLED, GLYCERIN

Accuracy	:	CL 2.5
Window	:	Plexi glass
Dampening liquid	:	Glycerin 99.7%

TEMPERATURE EFFECT

When temperature of the measuring system deviates from reference temperature (+20°C) max error $\pm 0.4\%$ / 10K of true scale value.

DIMENSIONAL DRAWING

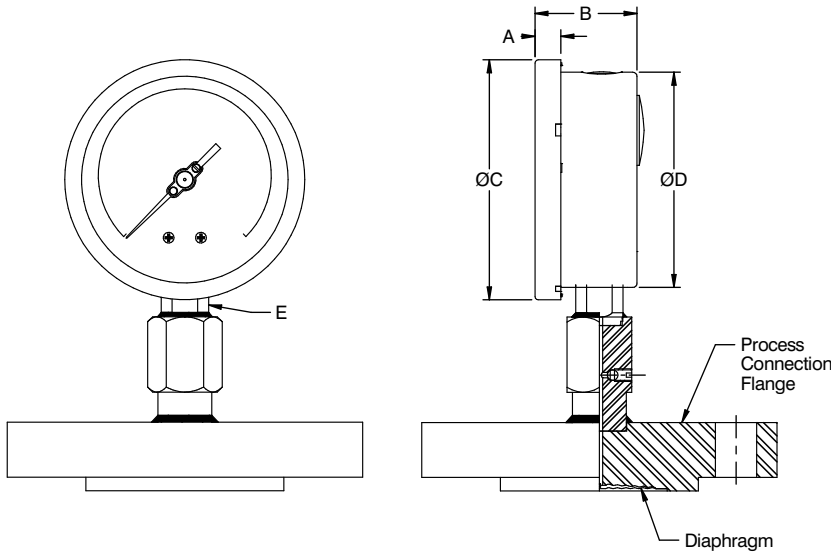

DN	A	B	ØC	ØD	E	Weight (grams)
100	12	48	111	100	SQ.22	5065
150	15	48	161	149	SQ.22	5363

All dimensions are in mm.

ORDERING CODES

1. DIAL SIZE

- 06 150 mm / 6"
- 04 100 mm / 4"

06

2. RANGE

- XXX Refer "Range Table"

XXX

3. MOUNTING PATTERN

- B0 Direct, Bottom connection

B0

4. PROCESS CONNECTION

- A25 1 1/2" RF 150#
- A26 1 1/2" RF 300#
- A27 1 1/2" RF 600#
- A31 2" RF 150#
- A32 2" RF 300#
- A33 2" RF 600#

A25

5. INGRESS PROTECTION

- ER IP 65

ER

6. EXECUTION

- EA Dry
- EB Dry but fillable, glycerine
- EC Dry but fillable, silicon oil²
- EG Dampening liquid filled, glycerine
- EH Dampening liquid filled, silicon oil²

EA

7. OTHER OPTIONS

- TA 5 - point calibration certificate
- XR Custom designed dial
- XT Dial tag marking
- TC Material test certificate 3.1
- TM Material test certificate 2.2
- XG SS tag plate, AISI 316 SS
- XF SS tag plate, AISI 304 SS
- RA Rubber parts, Viton
- RN Rubber parts, NBR

XX

Ordering Example : P704-06-XXX-B0-A25-ER-EA

NOTES

- 1. For other connections, please contact factory.
- 2. Rubber parts shall be in Viton.