

FEATURES

- Compact design
- Tig welded & hydro-tested
- Seamless pipes construction
- Threads welded

APPLICATION

- Heat dispenser for gauges, switches & transmitters
- Boilers

Compact



STANDARD SPECIFICATIONS

Type	: Pattern 1 (Coiled type)
Material	: AISI 316 SS
Instrument connection	: 1/2" BSP (F)
Pipe size & schedule	: Pipe 1/8" Sch 40
Connection type	: Swivel female
Process connection	: 1/2" BSP (M)
Maximum working pressure	: As per PT chart
Maximum working temperature	: As per PT chart

DIMENSIONAL DRAWING

Pattern 1

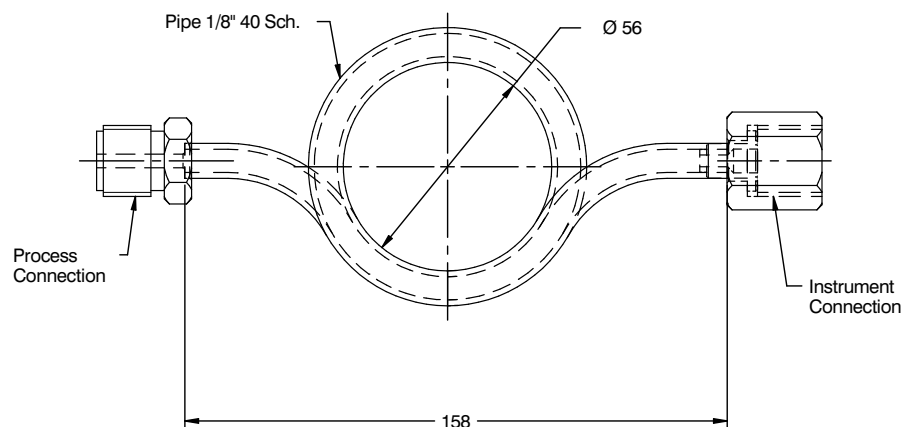

All dimensions are in mm.

ORDERING CODES

1. TYPE

1	Pattern 1 (Coiled type)	1
---	-------------------------	---

2. MATERIAL

MC	AISI 304 SS	MF
MF	AISI 316 SS	

3. INSTRUMENT CONNECTION

04B	1/2" BSP (F)	04B
04M	M20x1.5 mm (F)	

4. PIPE SIZE & SCHEDULE

UG	Pipe 1/8" Sch 40	UG
----	------------------	----

5. CONNECTION TYPE

C3	Swivel female	C3
----	---------------	----

6. PROCESS CONNECTION

14B	1/2" BSP (M)	14B
14N	1/2" NPT (M)	
14M	M20x1.5 mm (M)	

7. OTHER OPTIONS

TO	Certification for Oxygen service	XM
XM	Marking by engraving	

Ordering Example : A105-1-MF-04B-UG-C3-14B-XM

NOTES:

1. Other process connections are available through adaptors.