

## FEATURES

- Rigid construction
- Laser welded diaphragm
- Optional exotic materials

## APPLICATION

- Separation systems
- Isolation applications
- Viscous & corrosive media
- High-pressure applications
- High vibration application

### Ring Coupled

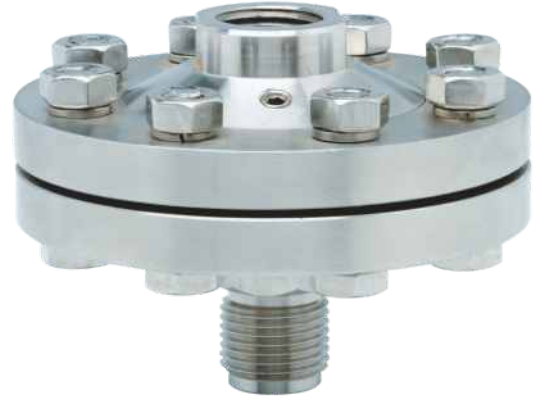

### STANDARD SPECIFICATIONS

Range type	: -1...0 bar & 0...21 bar / 0...70 bar
Top chamber material	: AISI 304 SS
Diaphragm	: AISI 316L SS
Gaskets	: PTFE
Bottom chamber material	: AISI 316 SS
Instrument connection	: 1/2" NPT (F)
Sealing fluid	: Silicon DC 200 (-40...205°C)
Process connection	: 1/2"NPT (M)
Coupling flanges & hardware	: Pressed Steel - Cup design (plated) / AISI 304 SS
Protection on wetted parts	: Optional
Assembly	: Direct
Capillary	: Optional
Armour	: Optional
Remote mounting length	: Optional

### DIMENSIONAL DRAWING

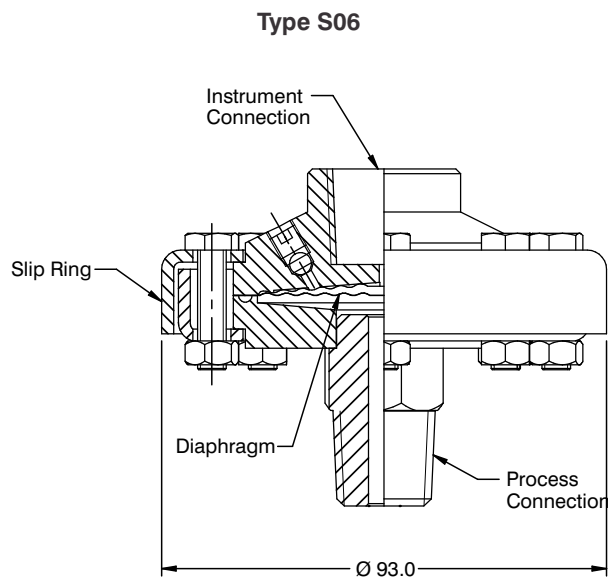

All dimensions are in mm.

DIMENSIONAL DRAWING

Type S07

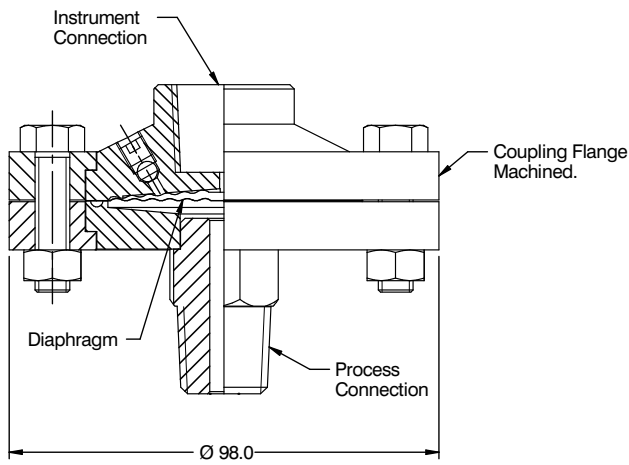

Type S08

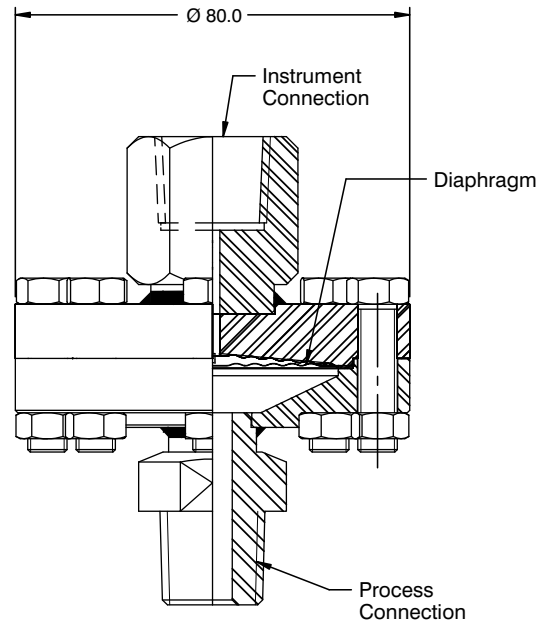

Type S09

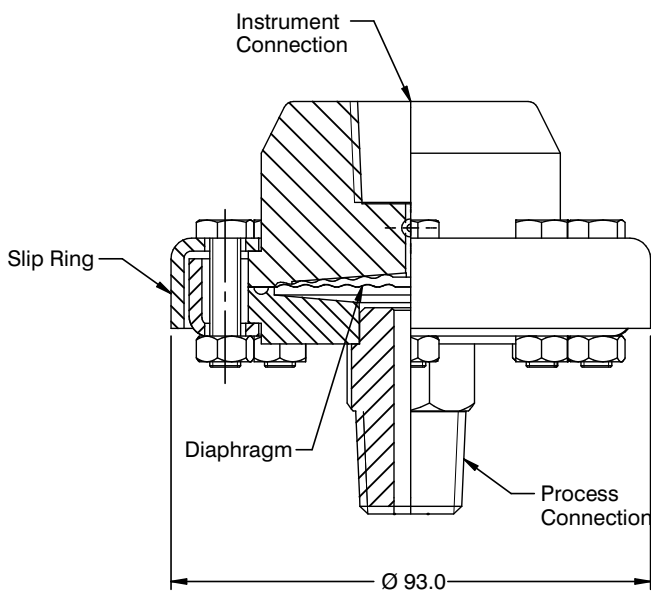

Type S10

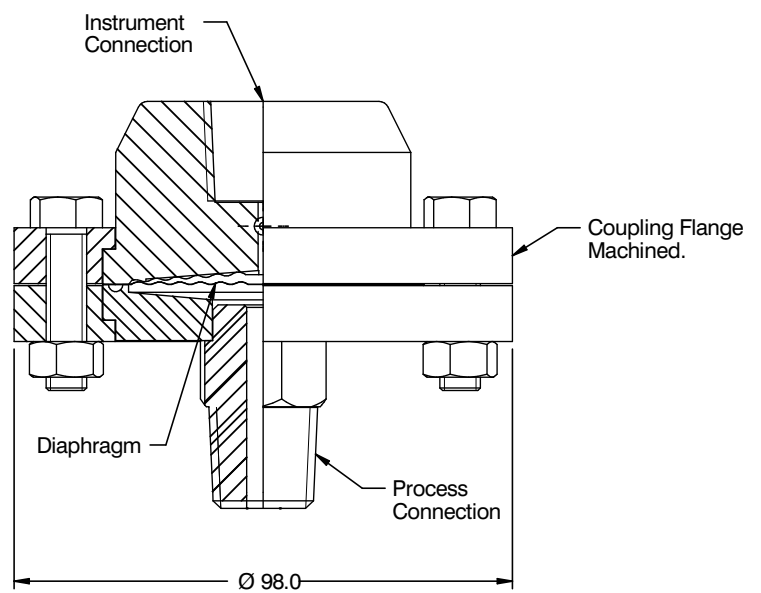

## ORDERING CODES

### 1. RANGE TYPE

<b>S06</b>	-1...0 bar & 0...21 bar
<b>S07</b>	-1...0 bar & 0...70 bar
<b>S08</b>	-1...0 bar & 0...160 bar

S06

### 2. TOP CHAMBER MATERIAL

<b>LC</b>	AISI 304 SS	<b>LF</b>	AISI 316 SS
<b>LG</b>	AISI 316L SS		

LC

### 3. DIAPHRAGM MATERIAL

<b>DG</b>	AISI 316L SS	<b>DM</b>	Monel 400
<b>DO</b>	Hastelloy C-276	<b>DQ</b>	Inconel 600
<b>DV</b>	Titanium	<b>DW</b>	Tantalum
<b>D8</b>	Silver coated		

DG

### 4. GASKETS

<b>RP</b>	PTFE	<b>RM</b>	Metal
-----------	------	-----------	-------

RP

### 5. BOTTOM CHAMBER MATERIAL

<b>NC</b>	AISI 304 SS	<b>NF</b>	AISI 316 SS
<b>NG</b>	AISI 316L SS	<b>NM</b>	Monel 400
<b>NO</b>	Hastelloy C-276	<b>NV</b>	Titanium
<b>NW</b>	Tantalum		

NF

### 6. INSTRUMENT CONNECTION

<b>03B</b>	3/8" BSP (F)	<b>04N</b>	1/2" NPT (F)
<b>02B</b>	1/4" BSP (F)	<b>04B</b>	1/2" BSP (F)
<b>02N</b>	1/4" NPT (F)		

04N

### 7. SEALING FLUID

<b>OA</b>	Silicon DC 200 [-40°C to 205°C]
<b>OF</b>	Food grade oil [-20°C to 140°C]
<b>OG</b>	Glycerine [10°C to 150°C]
<b>OI</b>	Syltherm 800 [-40°C to 315°C]
<b>OL</b>	Silicon DC 710 [7°C to 371°C]

OA

### 8. PROCESS CONNECTION

<b>12B</b>	1/4" BSP (M)	<b>13B</b>	3/8" BSP (M)
<b>14B</b>	1/2" BSP (M)	<b>12N</b>	1/4" NPT (M)
<b>14N</b>	1/2" NPT (M)	<b>02N</b>	1/4" NPT (F)
<b>04N</b>	1/2" NPT (F)	<b>02B</b>	1/4" BSP (F)
<b>04B</b>	1/2" BSP (F)	<b>12M</b>	M20X1.5mm(M)

14N

### 9. COUPLING FLANGES & HARDWARES

<b>L0</b>	Pressed Steel - Cup design (plated)
<b>LD</b>	AISI 304SS - Machined
<b>LH</b>	AISI 316 SS - Machined

L0

### 10. PROTECTION ON WETTED PARTS

<b>PA</b>	PTFE lining on bottom chamber <sup>3</sup>
<b>PB</b>	PTFE protection for diaphragm
<b>PC</b>	PTFE coating on diaphragm or wetted parts

XX

### 11. ASSEMBLY

<b>B8</b>	Direct
<b>B9</b>	Remote(capillary)

B8

### 12. CAPILLARY

<b>OU</b>	AISI 304 SS	<b>OV</b>	AISI 316 SS
-----------	-------------	-----------	-------------

XX

### 13. ARMOUR

<b>OX</b>	AISI 304 SS	<b>OY</b>	AISI 316 SS
<b>OZ</b>	PVC (Ambient max. 60°C)		

XX

### 14. REMOTE MOUNTING LENGTH

<b>XXXX</b>	1000 mm up to 6000 mm
-------------	-----------------------

XXXX

### 15. OTHER OPTIONS

<b>XZ</b>	Dry seal
<b>HL</b>	Helium leak test
<b>TM</b>	Material test certificate 2.2
<b>TC</b>	Material test certificate 3.1

XX

**Ordering Example : D102-S06-LC-DG-RP-NF-04N-OA-14N-L0-XX-B8**

#### NOTES:

- Other sealing liquids are available, contact factory for further details.
- All metal diaphragms are laser welded to the Top Chamber.
- While choosing option PA for diaphragm DG, option PB has to be selected mandatory.