

FEATURES

- Large volume type design
- Flushed diaphragm
- Laser welded diaphragm
- Optional flushing ring
- Optional exotic materials

APPLICATION

- Separation systems
- Isolation applications
- Viscous & corrosive media
- High-pressure applications
- High vibration application

Flushed Diaphragm



STANDARD SPECIFICATIONS

Range type	: -1...0 bar to 0...250 bar
Chamber / Flange material	: AISI 316 SS
Diaphragm	: AISI 316L SS
Instrument connection	: 1/2" NPT (F)
Sealing fluid	: Silicon DC 200 (-40...205°C)
Process connection	: 1 1/2" 150# as per ANSI B16.5
Flange facing type	: Raised face
Protection on wetted parts	: Optional
Assembly	: Direct
Capillary	: Optional
Armour	: Optional
Remote mounting length	: Optional

DIMENSIONAL DRAWING

Type S45

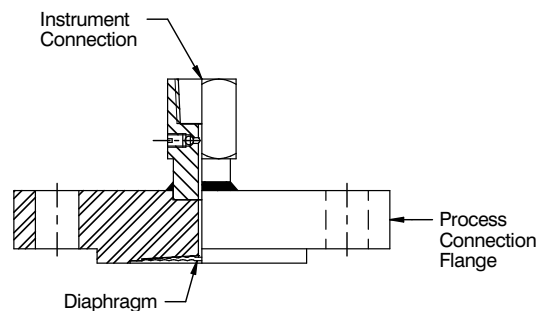

Type S46

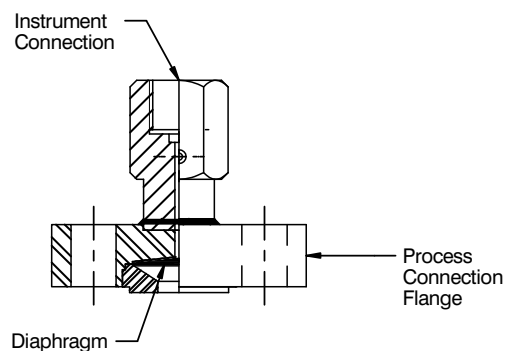

ORDERING CODES

1. RANGE TYPE

S45 -1...250 bar (Flange 1.5" & above)
S46 4...250bar (Flange ½" to 1")

S46

2. CHAMBER / FLANGE MATERIAL

LB ASTM A105	LC AISI 304 SS
LF AISI 316 SS	LG AISI 316L SS
LM Monel 400	LO Hastelloy C-276
LV Titanium	LW Tantalum

LC

3. DIAPHRAGM MATERIAL

DG AISI 316L SS	DM Monel 400
DO Hastelloy C-276	DV Titanium
DW Tantalum	

DG

4. INSTRUMENT CONNECTION

03B 3/8" BSP (F)	04N ½" NPT (F)
02B ¼" BSP (F)	04B ½" BSP (F)
02N ¼" NPT (F)	

04N

5. SEALING FLUID

OA Silicon DC 200 [-40°C to 205°C]
OF Food grade oil [-20°C to 140°C]
OG Glycerine [10°C to 150°C]
OI Syltherm 800 [-40°C to 315°C]
OL Silicon DC 710 [7°C to 371°C]

OA

6. PROCESS CONNECTION

XXX Refer Flange Table for the codes

A25

7. FLANGE FACING

F Flat Face
J Ring-Type Joint
R Raised Face
T Tongue and Groove (T&G)

R

8. PROTECTION ON WETTED PARTS

PA PTFE coating on flange
PC PTFE coating on diaphragm

XX

9. ASSEMBLY

B8 Direct
B9 Remote (capillary)

XX

10. CAPILLARY

OU AISI 304 SS	OV AISI 316 SS
-----------------------	-----------------------

XX

11. ARMOUR

OX AISI 304 SS	OY AISI 316 SS
OZ PVC (Ambient max. 60°C)	

XX

12. REMOTE MOUNTING LENGTH

XXXX 1000 mm up to 6000 mm

XXXX

13. OTHER OPTIONS

XZ Dry seal
HL Helium leak test
TM Material test certificate 2.2
TC Material test certificate 3.1

XX

Ordering Example : D202-S45-LC-DG-04N-OA-A25-R-XX-B8

APPLICABLE ACCESSORIES

A301 Flushing Ring

MOUNTING KITS

Hardware	Bolt / Nut / Washer
Flanges	Suitable mating type
Gaskets	Metal / Graphoil / Asbestos

NOTES:

- Other sealing liquids are available, contact factory for further details.
- All metal diaphragms are laser welded to the Top Chamber.