

Product introduction

Description



Main parameters

Measuring range	-50 - 400°C
Output signal	4-20mA, 4-20mA+HART, 1-5VDC, Modbus-RTU/RS485
Reference accuracy	±0.5% URL

Field of application

Temperature measurement

Measuring medium

The fluid which compatible with wetted parts

Technical Specifications

Measuring range and limit

-50-400°C, min measuring range 100°C
 Above measurement range can be replaced by °F or K units. Provide other measuring range according to requirements. Adjust requirements: lower range value (LRV) and upper range value (URV) can be adjusted within the scope of the upper and lower range limit, smallest calibratable span $\leq |URV-LRV| \leq$ upper range limit.

Standard specifications and reference conditions

Test standard: GB/T30121 / IEC60751; Zero based-calibration span, 4-20mA analog output

Performance specifications

The overall performance including but not limited to 【reference accuracy】 , 【environment temperature effects】 and other comprehensive error
 Typical accuracy: $\pm 0.5\%$ URL
 Stability: superior to $\pm 0.05\%$ URL or 0.1°C/year, whichever is greater@ under the checking condition

Reference accuracy

Including linearity, hysteresis and repeatability. calibration temperature: 20°C \pm 5°C

Linear output accuracy	Typical	$\pm 0.5\%$ URL	Full scale

Ambient temperature effects(reference accuracy: 22°C)

$\leq \pm 0.005\%$ URL/°C, temperature 22°C

Power supply effects

$\leq \pm 0.01\%$ URL/V, power supply 24V(refer to full scale output 20mA)

Loading effects

$\leq \pm 0.02\%$ URL/100Ω(refer to full scale output 20mA)

Vibration effects

According to IEC60068-2-6 , 4g/2...100HZ

Output signal

Signal	Type	Output
4-20mA	Linearity	Two wire
4-20mA+HART	Linearity	Two wire
1-5VDC	Linearity	Three wire
Modbus-RTU/RS485	Linearity	Four wire

Insulation resistance

$\geq 20M \Omega$ @ reference, 100VDC

Power supply

Items	Operating conditions
Standard	10-30VDC
Power consumption	$\leq 500mW$ @24VDC, 20.8mA

Damping time

Total damping time constant: equal to the sum of damping time of amplifier and sensor capsule
 Reaction time: $\leq 10s$ @ water flow 0.4m/s, outer diameter: 6mm

Technical Specifications

Environment condition

Items	Operational condition
Working temperature	-40-85°C, integrated LCD display: -20-70°C
Storage temperature	-40-100°C, integrated LCD display: -20-70°C
Working humidity	0-95%RH
Proction class	Aluminum-alloy terminal, IP67

Reaction time(Test standard: IEC60751, ≤10s@ water flow 0.4m/s)

Thermal protection tube				
Outer diameter	Reaction time	Reducing pipe 5.3mm	Cone-shaped tube 6.6mm or 9mm	Straight tube
10mm(wall thickness 1 mm)	t50	7.5s	11s	18s
	t90	21s	37s	55s
12mm(wall thickness 1 mm)	t50	7.5s	-	18s
	t90	21s	-	55s
16mm(wall thickness 1 mm)	t50	-	11s	38s
	t90	-	37s	125s

Note: The reaction time above don't include the reaction time of temperature transmitter.

Mounting requirements

Mounting direction	None
Mounting position	Pipe, tube or others
Insertion length*	The smallest insertion length should 8 times outer diameter of thermal protection tube, and the end of the probe should reach or surpass the pivot of the tube.

*Please consider technique datas and process connection parameters(such as medium flow rate、 process pressure and so on) before confirm the insertion length of the transmitter.

Process pressure(The process pressure beared by thermal protection tube changes along with medium temperature, see chart below)

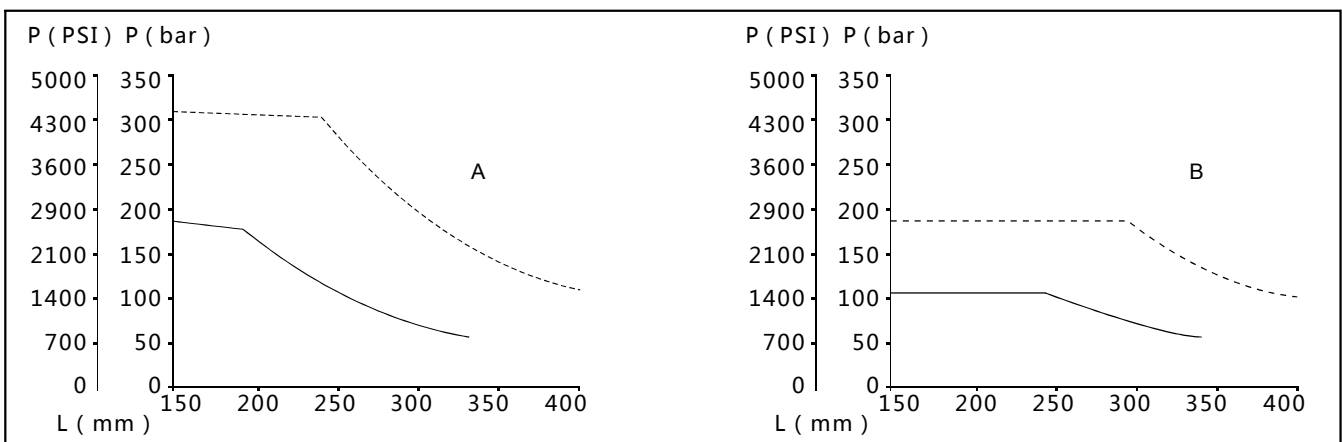

—————	Tube diameter 10mm	tube wall thickness 1mm	A: water, T=50°C	L: immersion depth
- - - - -	Tube diameter 12mm	tube wall thickness 2mm	B: superheated steam, T=400°C	P: process pressure

Disclaimer: all the data used in the product description is not legally binding. Relevant technical details may be changed due to further improve

Technical Specifications

Maximum medium flow rate(The maximum medium flow rate beared by thermal protection tube reduces with insertion length increases, see chart below)

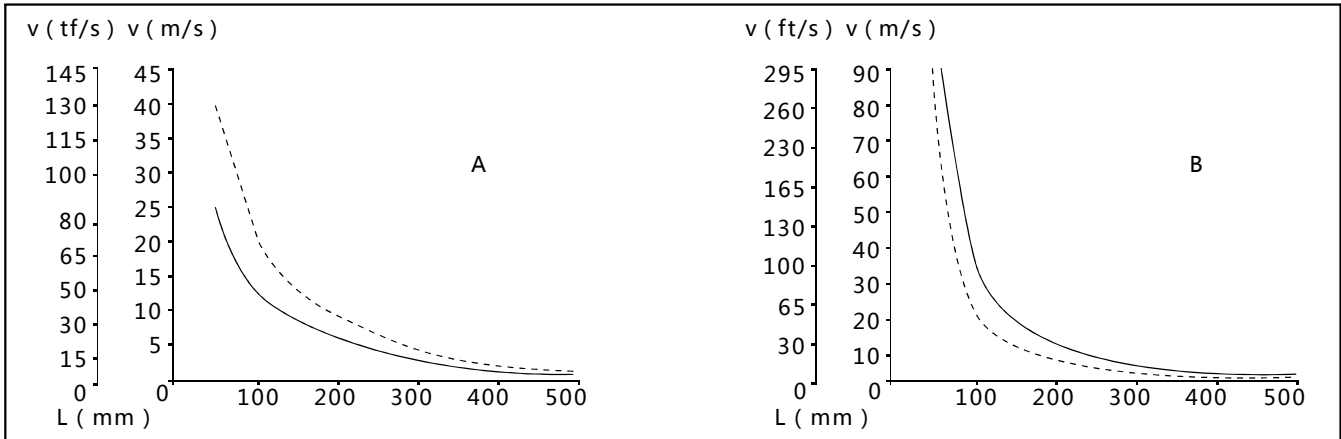

—————	Tube diameter 10mm	tube wall thickness 1mm	A: water, T=50°C	L: immersion depth
-----	Tube diameter 12mm	tube wall thickness 2mm	B: superheated steam, T=400°C	V: flow rate

EMC environment(not RS485 signal output)

NO.	Test items	Basic standards	Test conditions	Performance level
1	Radiated interference	GB/T 9254/CISPR22	30MHz-1000MHz	OK
2	Conducted interference (DC power port)	GB/T 9254/CISPR22	0.15MHz-30MHz	OK
3	Electrostatic discharge immunity test (ESD)	GB/T 17626.2/IEC61000-4-2	4kV(Contact),8kV(Air)	B(Note2)
4	Immunity to radio frequency EM-fields	GB/T 17626.3/IEC61000-4-3	10V/m(80MHz-1GHz)	A(Note1)
5	Power frequency magnetic field Immunity test	GB/T 17626.8/IEC61000-4-8	30A/m	A(Note1)
6	Electrical fast transient / Burst Immunity test	GB/T 17626.4/IEC61000-4-4	2kV(5/50ns,100kHz)	B(Note2)
7	Surge immunity requirements	GB/T 17626.5/IEC61000-4-5	1kV(Line to line) 2kV(Line to ground) (1.2us/50us)	B(Note2)
8	Immunity to conducted disturbances induced by radio frequency fields	GB/T 17626.6/IEC61000-4-6	3V(150kHz-80MHz)	A(Note1)

(Note 1)Performance level A: The preformance within the limits of normal technical specifications.

(Note 2)Performance level B: Temporary reduction or loss of functionality or preformance, it can restore itself. The actual operating conditions, storage and data will not be changed.

Product selection instruction

Pressure sensor types

Code	Nominal value	Description
R1	Sensor types	PT100RTD

Transmission module

Code	Items	Description
F	Output signal	4-20mA two wire, power supply: 10-30VDC
H		4-20mA+HART two wire, power supply: 10.5/16.5-30VDC
1		1-5VDC Three wire, power supply: 12-30VDC
R		Modbus-RTU/RS485 Four wire, power supply: 5/9-30VDC
C	Display	With LCD display
A		Without display

Display module(C)



Display module(C)

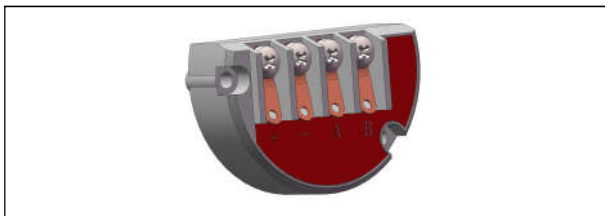

Extension tube selection

Code	Items	Description
Q1	Specifications	None
Q2		Material: SUS304, length: 50mm, outer diameter: Φ12
Q3		Material: SUS304, length: 100mm, outer diameter: Φ12
Q4		Material: SUS304, length: 150mm, outer diameter: Φ12
Q5		Material: SUS304, length: 200mm, outer diameter: Φ12

Extension tube length

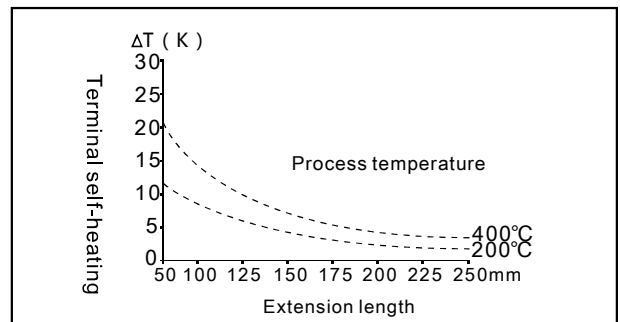

The relation chart of thermal resistance terminal self-heating and process temperature

Terminal temperature= environment temperature+ terminal self-heating

Electrical connection select instruction

Code	Item	Description
T1	Electrical connection	Aluminum-alloy terminal, 2 cable entry, M20*1.5(F), red body, white cover
R1	Cable entry protector	Waterproof connector M20*1.5 one side, blind plug another side, PVC material, 6-8mm diameter cable only, IP67
R2		Flame proof, 1/2 NPT(F) one side, blind plug another side, stainless steel material, 6-8mm diameter cable only, IP67
R3		Flame proof, M20X1.5(F) one side, blind plug another side, stainless steel material, 6-8mm diameter cable only, IP67

Product selection instruction

Housing(T1)

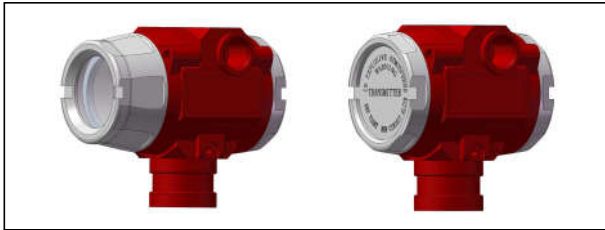

Standard cable entry adaptor (R1)

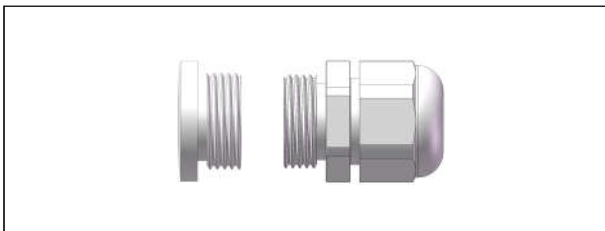

Flame-proof cable entry adaptor (R2/R3)

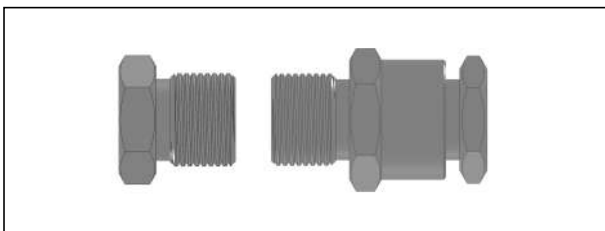

Process connection select instruction

Code	Items	Description
G	Mounting type	Fixed process connection mounting
H	Material	Movable process connection mounting
4		SUS304
6	Process connection specifications	SUS316
M01		M20*1.5(M), GB/T192-2003
G01		G1/2(M), EN837
R01		G1/2-14NPT, ANSI/ASME B1.20.1
H01		Flange HG/T20592-2009 DN50PN10-PN40
H02		Flange HG/T20592-2009 DN50PN10-PN40

Insertion probe select instruction

Code	Items	Description
D1	Outer diameter	Diameter: 6mm, probe material is same as process connection material
D2		Diameter: 8mm, probe material is same as process connection material
D3		Diameter: 10mm, probe material is same as process connection material
D4		Diameter: 12mm, probe material is same as process connection material
D5		Diameter: 16mm, probe material is same as process connection material
LXXXX	Insertion length	Customized insertion length: 0 < LXXXX < 3000mm, samples: 80mm=L0080, the minimum gap is 50mm of customized insertion length. Default insertion length includes thread specifications

Product drawing and dimension

Drawing and dimension (thread) with display(C) (unit:mm)

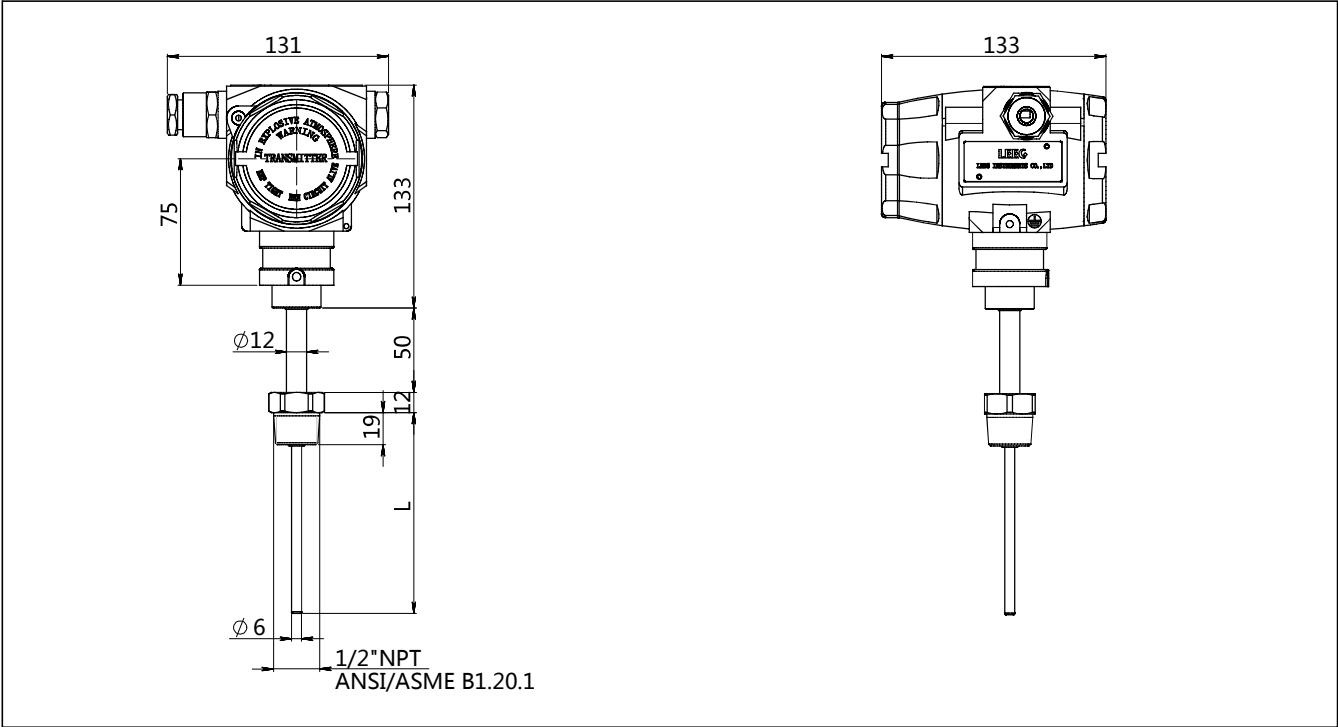

Drawing and dimension (flange) with display(C) (unit: mm)

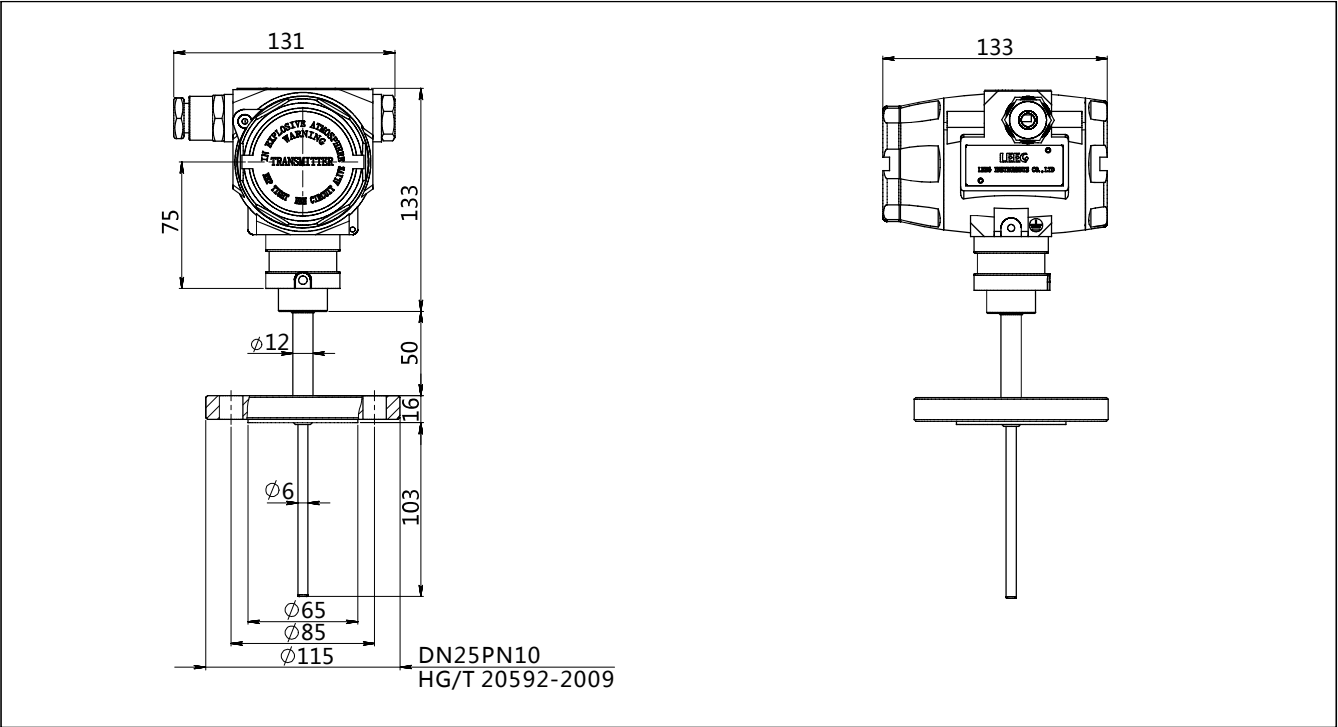

Disclaimer: all the data used in the product description is not legally binding. Relevant technical details may be changed due to further improve

Product drawing and dimension

Drawing and dimension (thread) without display (A) (unit:mm)

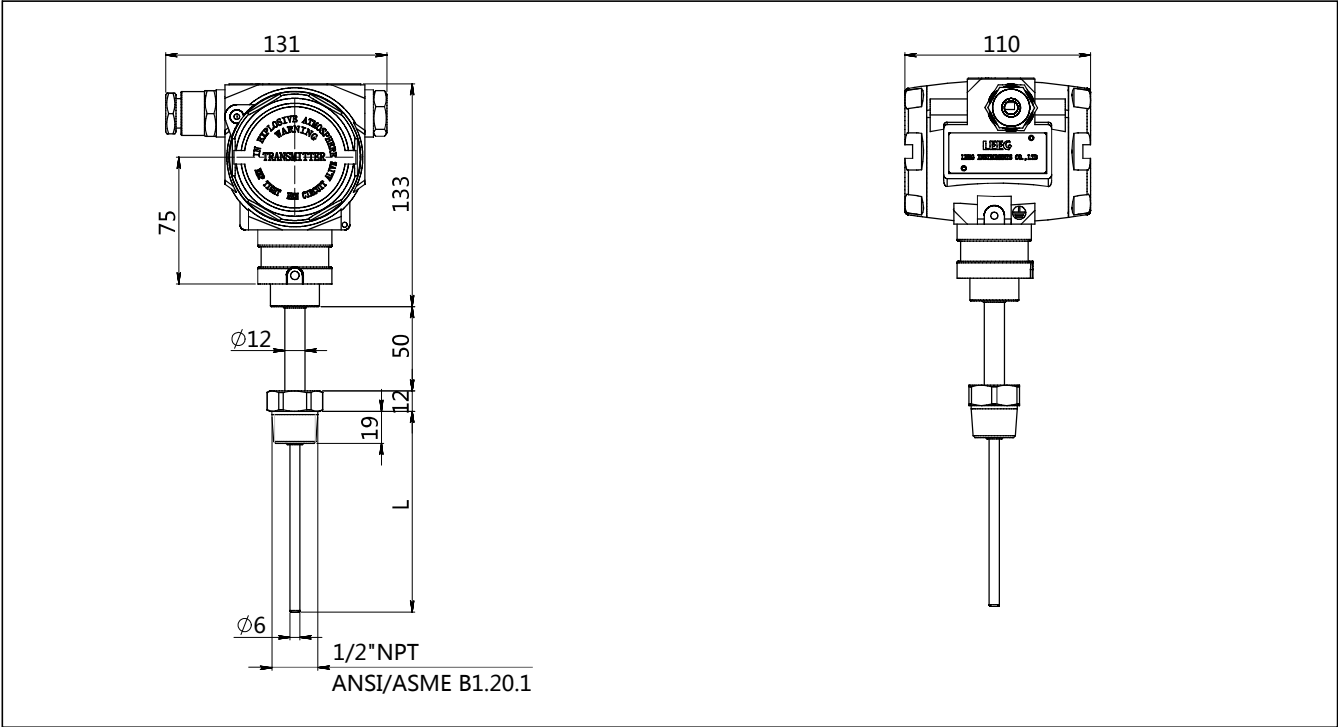

Drawing and dimension (flange) without display (A) (unit:mm)

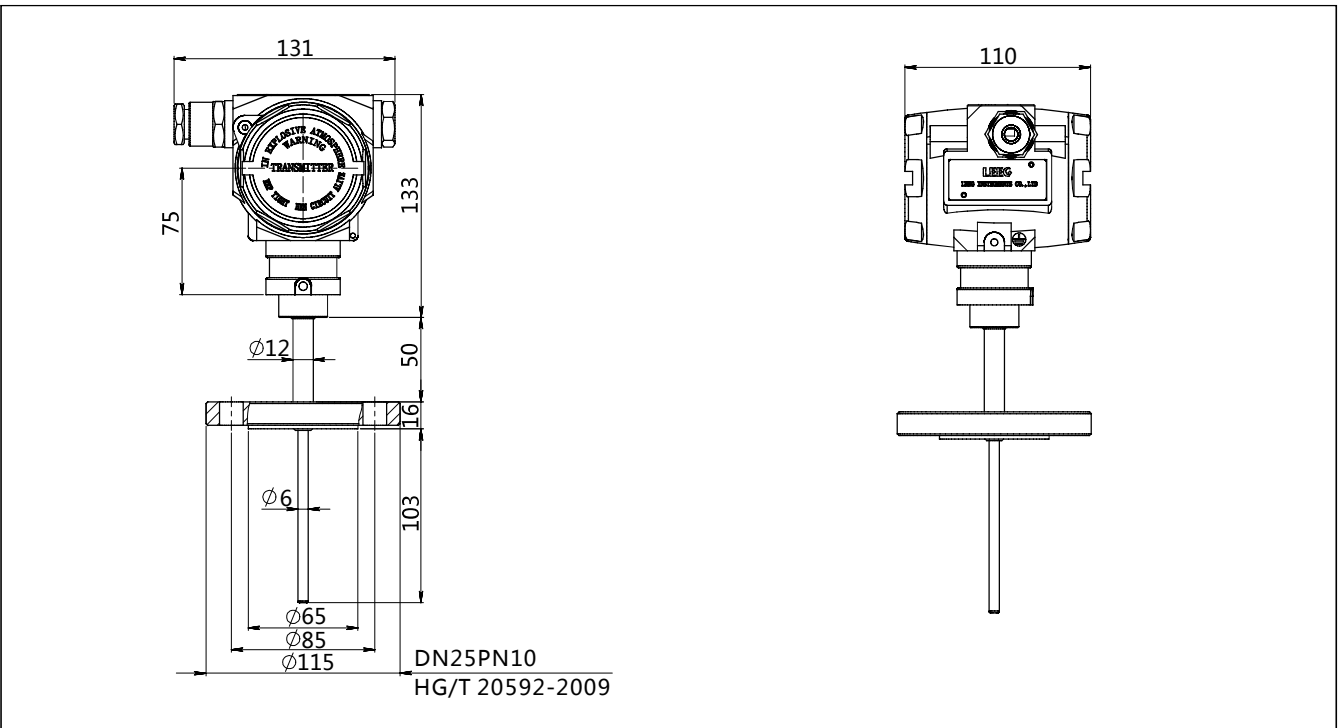

Disclaimer: all the data used in the product description is not legally binding. Relevant technical details may be changed due to further improve

Product drawing and dimension

Process connection(M01) (unit: mm)

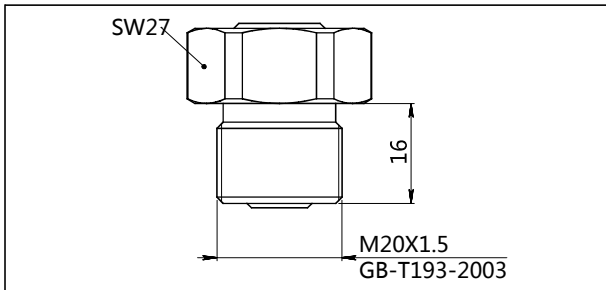

Process connection(G01) (unit: mm)

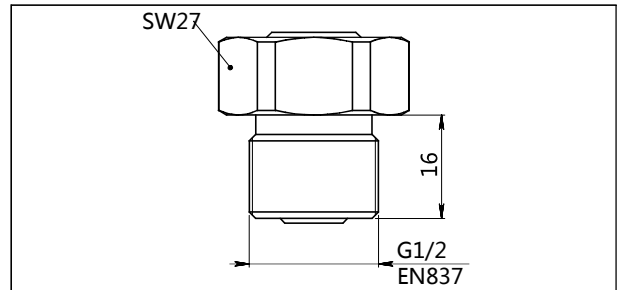

Process connection(R01) (unit: mm)

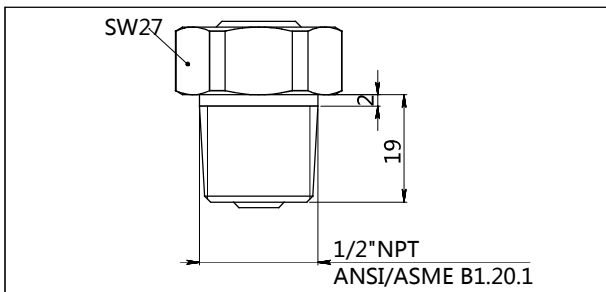

Process connection(H01-H02) (unit: mm)

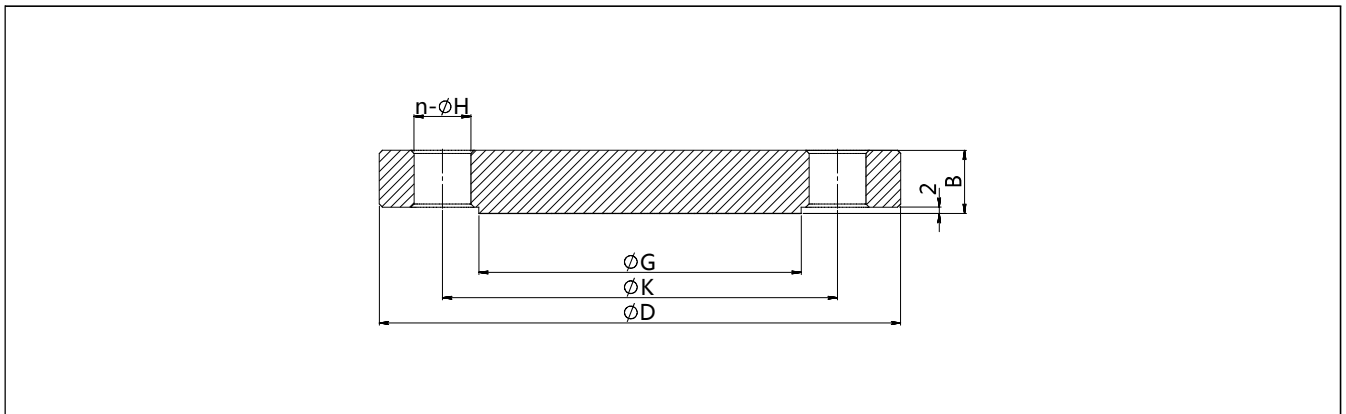

Standard	Specification	Outer diameter (φD)	Thickness (B)
HG/T20592-2009	DN50PN10-PN40	165	20
HG/T20592-2009	DN25PN10-PN40	115	16
Hole circle(φK)	Raised-face diameter(φG)	Hole diameter(φH)	Number(n)
125	102	18	4
85	68	14	4

Ordering information chapter

Item	Parameters	Code	Instruction	(*) Fast delivery available
	Model	LG200-WRT	Integrated thermal resistance temperature transmitter	
Sensor	Separator	-	Detailed specifications as following	
	Pressure range code	R1	PT100RTD	*
Electrical connection	Separator	-	Detailed specifications as following	
	Electrical connection	T1	Aluminum-alloy terminal, 2 cable entry, M20*1.5(F), red body, white cover	
	Cable entry protection	R1	Waterproof connector M20*1.5 one side, blind plug another side, PVC material, 6-8mm diameter cable only, IP67	*
		R2	Flame proof, 1/2 NPT(F) one side, blind plug another side, stainless steel material, 6-8mm diameter cable only, IP67	*
		R3	Flame proof, M20X1.5(F) one side, blind plug another side, stainless steel material, 6-8mm diameter cable only, IP67	
Output	Separator	-	Detailed specifications as following	
	Output signal	F	4-20mA two wire, power supply: 10-30VDC	*
		H	4-20mA+HART two wire, power supply: 10.5/16.5-30VDC	
		1	1-5VDC Three wire, power supply: 12-30VDC	
		R	Modbus-RTU/RS485 Four wire, power supply: 5/9-30VDC	
	Display	C	With LCD display	*
		A	Without display	
Extension pipe	Separator	-	Detailed specifications as following	
	Extension pipe length	Q1	None (suitable temperature: -40°C-85°C)	
		Q2	Material: SUS304, length: 50mm, outer diameter: Φ12	*
		Q3	Material: SUS304, length: 100mm, outer diameter: Φ12	
		Q4	Material: SUS304, length: 150mm, outer diameter: Φ12	
		Q5	Material: SUS304, length: 200mm, outer diameter: Φ12	
Process connection	Separator	-	Detailed specifications as following	
	Mounting type	G	Fixed process connection mounting	*
		H	Movable process connection mounting	
	Material	4	SUS304	*
		6	SUS316	
	Specification	M01	M20*1.5(M), GB/T192-2003	*
		G01	G1/2(M), EN837	*
		R01	1/2-14NPT, ANSI/ASME B1.20.1	*
		H01	Flange HG/T20592-2009 DN50PN10	*
		H02	Flange HG/20592-2009DN25PN10	*
Insertion probe	Separator	-	Detailed specifications as following	
	Outer diameter	D1	Diameter: 6mm, probe material is same as process connection material	*

Disclaimer: all the data used in the product description is not legally binding. Relevant technical details may be changed due to further improve

Ordering information chapter

		D2	Diameter: 8mm, probe material is same as process connection material	*
		D3	Diameter: 10mm, probe material is same as process connection material	
		D4	Diameter: 12mm, probe material is same as process connection material	
		D5	Diameter: 16mm, probe material is same as process connection material	
	Insertion length	LXXXX	Customized insertion length: 0 < LXXXX < 3000mm, samples: 80mm=L0080, 150mm=L0150	
Additional options	Separator	-	Detailed specifications as following	
	Calibration report	/Q1	Calibration report provided by our company	
	Approvals	/E1	Flame proof certificate, ExdIICT6, NEPSI	
	Wetted parts treatment	/G1	Ungrease treatment	
		/G1	Electropolishing treatment	

Factory settings and parameters

Item	Menu mark	Factory setting value
Tag position	None	0(No specific settings)
Analog output type	mA	Liner(No specific settings)
Display mode	DISP	PV(No specific settings)
Alarm signal	ALARM	No(No specific settings)

Item	Menu mark	Factory setting value
Damping value	DAMP	0(No specific settings)
4mA Lower range value	LRV	According to the order value
20mA Upper range value	URV	According to the order value
Process unit	U	According to the order

Flame proof certificate

Certification organization	NEPSI
License scope	LG200-W series temperature transmitter
Explosion-proof mark	ExdIICT6
Working environmental temperature	-25-+60°C
Registration number	GYB16.1254X