

## FEATURES

- 1 SPDT contact
- Weatherproof to IP 67
- Field adjustable set point
- High Accuracy / Repeatability

## APPLICATION

- Earth movers
- OEM industries
- Lubrication industries
- Hydraulic equipments
- Pneumatic machineries
- Automobile applications

### OEM Industry Applications



### STANDARD SPECIFICATIONS

|                             |   |  |
|-----------------------------|---|--|
| Repeatability               | : | ± 1.0 % F.S  |
| Measurement unit            | : | bar  |
| Range                       | : | Refer "Range Table"  |
| Differential                | : | Fixed  |
| Mounting                    | : | Bottom / Panel   |
| Enclosure Material          | : | Aluminum pressure die cast   |
| Sensing Elements            | : | SS 316 Diaphragm   |
| Switch                      | : | 1 SPDT Snap action micro switch  |
| Switch Rating               | : | 5A,250 VAC / 0.2A,24 VDC   |
| Process Connection          | : | 1/4"BSP(F)   |
| Maximum Process Temperature | : | 150 °C   |
| Ambient Temperature         | : | -10...60 °C  |
| Cable entry                 | : | PG - 7   |
| Set point                   | : | Between 20 to 80 % F.S for better performance                          |
| High Voltage Strength       | : | 0.5 to 0.6 KV between open contacts and 2 K V between contact and body |

### RANGE TABLE

| CODE | Range<br>"bar" |
|------|----------------|
| B04  | 0.2...2        |
| B06  | 0...4          |
| B07  | 0.6...6        |
| B09  | 1...10         |
| B11  | 1...16         |
| B13  | 2...25         |
| B15  | 2...32         |
| B16  | 4...40         |
| B17  | 5...60         |
| B19  | 10...100       |

DIMENSIONAL DRAWING

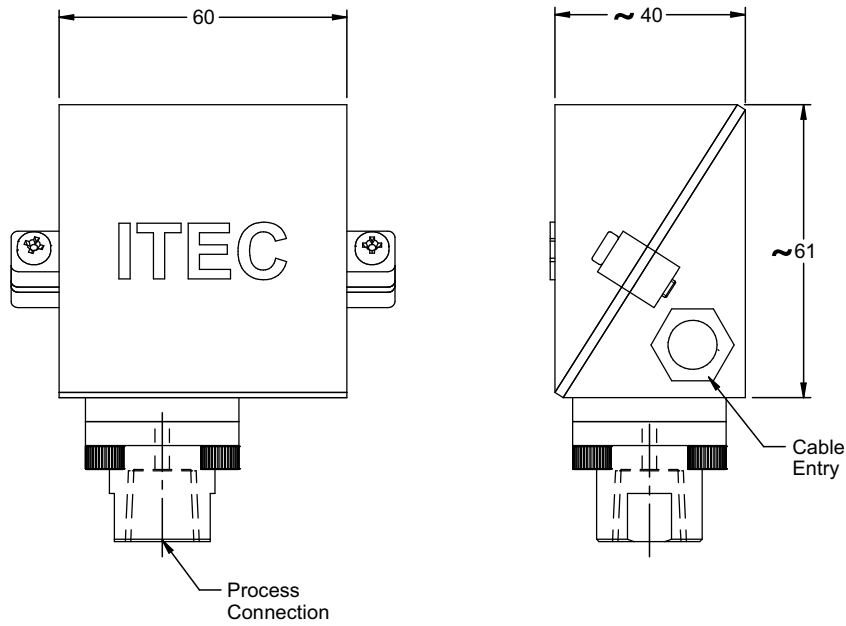

All dimensions are in mm

ORDERING CODES

1. RANGE

Refer "Range Table"

B09

2. CHAMBER MATERIAL

- NC AISI 304 SS
- NF AISI 316 SS

NC

3. SENSING ELEMENT MATERIAL

- DF AISI 316 SS
- DG AISI 316L SS

DF

4. CONNECTION

- 02B 1/4" BSP (F)
- 12B 1/4" BSP (M)
- 13B 3/8" BSP (M)
- 14B 1/2" BSP (M)
- 12N 1/4" NPT (M)
- 13N 3/8" NPT (M)
- 14N 1/2" NPT (M)

02B

5. OTHER OPTIONS

- TB Calibration Certificate
- XF AISI 304 SS tag plate

XX

Ordering Example : S104-B09-NC-DF-02B

NOTES:

- 1. Other connections are available through adaptors.

Rev 00

© 2014 ITEC. All rights reserved. Technical changes and errors are expected.