



## Intelligent Level Sensor for Pharmaceutical / F&B



# PRODUCT INTRODUCTION

## PRINCIPLE

The sensor's working principle by sending "scan-frequency", different material emits different frequency, therefore, the sensor will send the switch signal while it's powered by material.

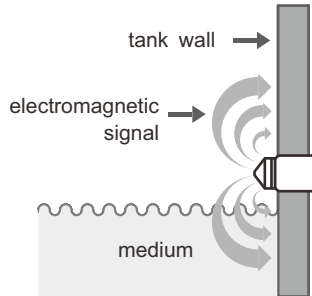

## FEATURE

- Easy installation by standard connection with IP67/IP68/IP69K as protection grade.
- Compact design, easy carry; can be installed in narrow space or stringent operation condition.
- The surface roughness (Ra) can be customized and applicable for Chemical & pharmaceutical and food processing industries.
- With magnetic test function to examine wiring and operation condition in real time.
- Durable stainless housing.
- Real time site-control by LED indicators.
- Overcurrent protection detects over current and shut down the output immediately.
- Workable in CIP and SIP cleaning environment.
- Unaffected by foam and viscous medium.
- Applicable to measure the single-point level of liquid, viscous medium and powder medium in the container and pipe; also providing pump dry run protection.
- It provides 2 output signals and the sensitivity can be set independently; which helps detect 2 kinds of medium.  
(For instance: Oil and water.)
- Acquired NEPSI dust Explosion-proof certificate, Ex tD A20 IP67 T85°C T<sub>200</sub> 100°C.

## APPLICATION

With high/low level of material in the process tank or pipeline, alarm of empty material or switch output is particularly suitable for application in the following industries:

- Food manufacturing
- Beverage manufacturing
- Pharmaceutical manufacturing.

## INSTALLATION DIAGRAM

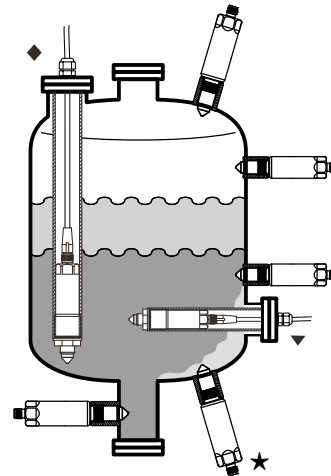

Tank Diagram

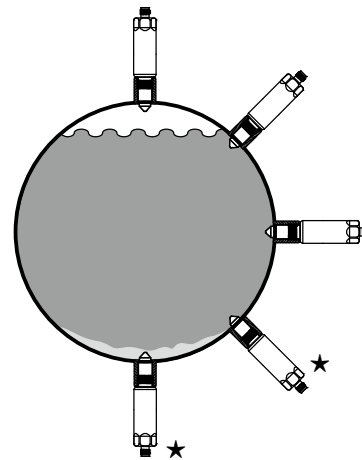

Pipeline Diagram

Top diagram shows the sensors installed in the tank for level detection or dry running protection.

Below diagram shows the sensors installed in the pipeline for level detection or alarm for not full pipe.

### Note!

1. If the medium with strong viscosity or there is sediment, the installation position shows ★ is not suggested. It may generate failure output signal due to the residue monitored as liquid.
2. For top-mounted installation, the rear-mounted type with the extension of the auxiliary rod can be installed at a lower position (◆: the auxiliary rod is not included in the order).
3. The rear-mounted auxiliary rod extends through the sediment can prevent from severe bridging. (▼: auxiliary rod is not included in the order).

# APPLICABLE MEDIUM FORM

Following form, please kindly choose the medium and corresponded default setting. Always ensure the correct setting and corresponded medium.

Attention!! It may cause failure result or unstable operation condition if the application NOT follow the operation range. ● means you can measure the medium based on FineTek default setting.

	Item	Water Based	Low Moisture/ Sugar Content	Oil Based/ Powder
1	Tap water	●		
2	Seawater	●		
3	Pure water	●		
4	Beer	●		
5	Wine	●		
6	Liquor(40%)		●	
7	Juice (Stock)	●		
8	Juice (Distillate)	●		
9	Milk	●		
10	Yoghurt Drink	●		
11	Vinegar	●		
12	Condensed Milk 7.5%	●		
13	Chocolate(40°C)		●	
14	Syrup		●	
15	Honey		●	
16	Fructose	●		
17	Albumen	●		
18	Yolk		●	
19	Egg(Liquid)	●		
20	Jam(Almond)	●		
21	Jam(Strawberry)	●		
22	Barbecue Sauce	●		
23	Soy Sauce	●		
24	Flour			●
25	Starch			●
26	Cocoa Powder			●
27	Coffee Powder			●
28	Hazelnut Powder(40°C)			●
29	Pepper(Ground)			●
30	Mashed Potatoes			●
31	Creamer(Powder)			●
32	Salt			●
33	Caster Sugar			●
34	Crystal Sugar(Ground)			●
35	Mayonnaise			●
36	Butter		●	
37	Olive Oil			●
38	Palm Oil			●
39	Canola Oil			●
40	Sunflower Oil			●
41	Linseed oil			●
42	Glycerin	●		
43	Mineral Oil(15W40)			●
44	Acetone		●	
45	Methanol	●		
46	Ethanol	●		

# STANDARD SPECIFICATIONS

	Normal (Standard type/ Extension type/ Mini type)	Rear install type	Explosion proof type
Scope (optional)	Water-based media, oil-based media, powder media, dual-level media (such as oil+water), fluid with separation layer (such as bubbles)		Powder media
Ambient temperature	-40~85°C(-40~185°F)	-40~80°C(-40~176°F)	-20°C~70°C(-4°F~158°F)
Process temperature	Continuous: max.100°C while ambient temp. -40°C~85°C (-40°F~185°F) Short time(1hr): max.150°C (Mini type: max.135°C) while ambient temp. -40°C~ 60°C (-40°F~140°F)	-40~80°C(-40~176°F)	Max.100°C while ambient temp.: -20°C~70°C (-4°F~158°F)
Rated voltage	18VDC~30VDC		
Power consumption	Max. 50mA		
Over voltage protection	overvoltage category II		
Reversal protection	Yes		
Switch output (optional)	2 switches: 1 <sup>st</sup> NO mode and 2 <sup>nd</sup> NC mode.		
Output mode	PNP/NPN (optional)		
Switch delay function	<1 second(maximum 60 seconds)		
Output load current	Max. 100 mA		Max. 50 mA
Voltage drop	Max. 2.5V		
Short-circuit protection	Yes, short-time pulse		
Overload protection	Yes		
Electric connection	M12 4PIN connector		
Wetted material (optional)	SUS316 \ SUS316L		
Process pressure	-1~40 bar		
Contact specification	G 1/2"	M32*P1.5	G 1/2"
Probe material/surface Roughness	PEEK/Ra<0.8		PEEK-1000/Ra<0.8
Housing protection (optional)	IP67/IP68/IP69K (Under water 1meter, IP68 can last for 30 days).		
LED Indicator	Yellow LED for starting, Green LED for resetting		
Simulation output test (not available for mini type)	Magnetic test (lean a magnet close to the + sing for 2 seconds, there will be switching output)		
Digital communication	IO Link V1.1		
Standard compliance	IEC61000-4-2, IEC61000-4-4, IEC61000-4-11		
Explosion-proof certificate	N/A		 NEPSI Ex tD A20 IP67 T85°C T <sub>200</sub> 100°C

## Warning !

1. Only Explosion-proof type can be installed and used in Combustible dust explosion environment.
2. The sensor must be installed with the exclusive "Thread connector" or "Thread adapter", in order to ensure the installation sensor operate normally and avoid leakage.
3. The electrical connection of this device has achieved IP68/IP69K protection grade, so it must be connected with the corresponding M12 connection cable in order to be installed effectively.
4. Explosion-proof type must be installed with M12 connection cable approved by NEPSI, in order to use it in the explosion environment (please refer to chapter Accessories - Thread Connector/ ADAPTOR").
5. Please refer to the " SIS Sanitary Intelligent Level Switch Operation Instruction" for the installation and operation of the product

# DIMENSIONS

## Standard type

(Unit: mm)

Applied for general medium

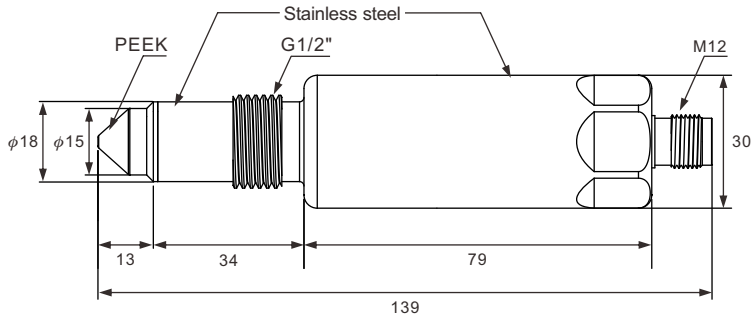

## Extension type

Applied for sticky medium or easily build up medium

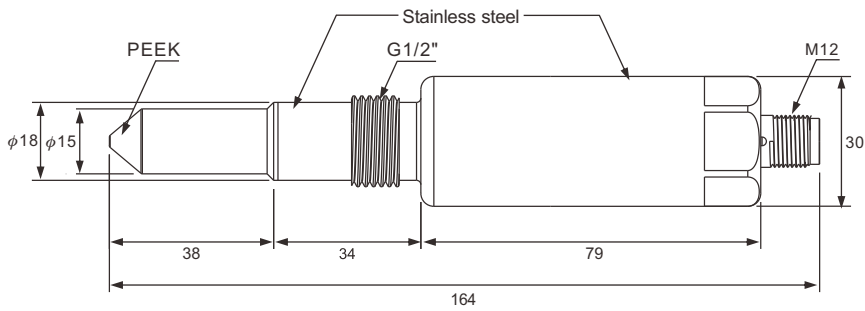

## Mini type

Applied for general medium narrow space

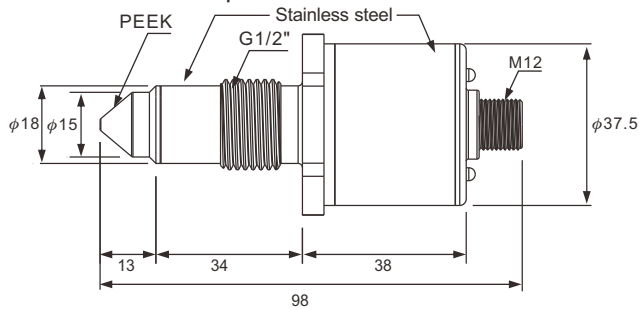

## Rear install type

Suitable for no hole on the side or installation extension to prevent from severe bridging.

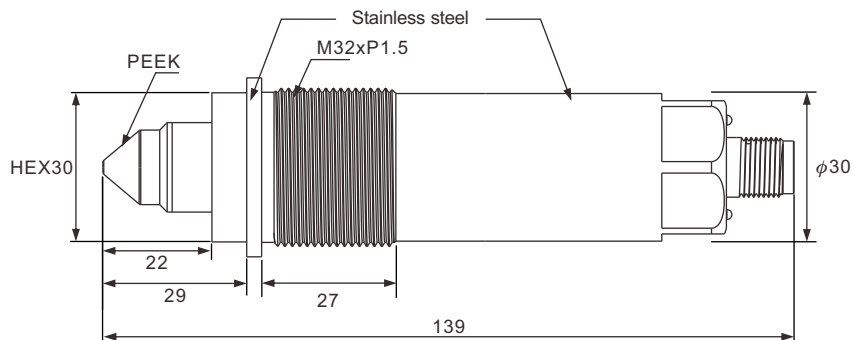

# FUNCTIONS

Transistor output	Alarm	Detected level	Output	Output signal	LED indicator
PNP	MAX		OUT1		Green
			OUT2		Yellow
			OUT1		Yellow
			OUT2		Green
	MIN		OUT1		Green
			OUT2		Yellow
		OUT1		Green	
		OUT2		Yellow	
NPN	MAX		OUT1		Green
			OUT2		Yellow
			OUT1		Yellow
			OUT2		Green
	MIN		OUT1		Yellow
			OUT2		Green
		OUT1		Green	
		OUT2		Yellow	

- Correspondence output table: OUT 1 sets as NO; OUT 2 sets as NC.
- IL indicates load enabled.

## SIMULATION OUTPUT TEST

1. Finished the installation and supply the sensor with 18~30Vdc.
2. Lean a magnet close to the + sign for 2 seconds or more, there will be switching output with corresponding LED light display.
3. Remove the magnet from the + sign, the switching output and corresponding LED light display will return to normal status.

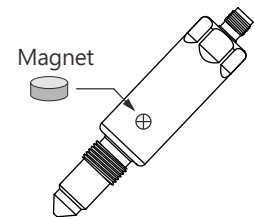

## WIRING DIAGRAM

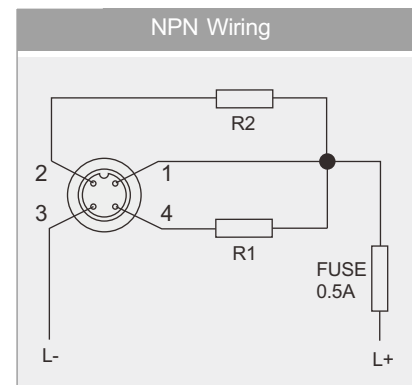
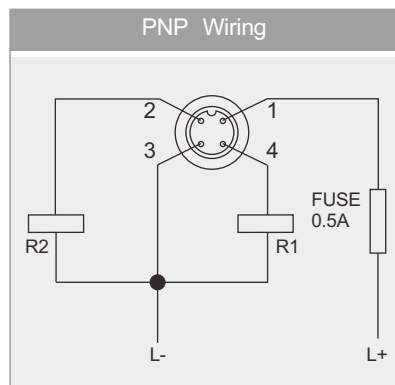
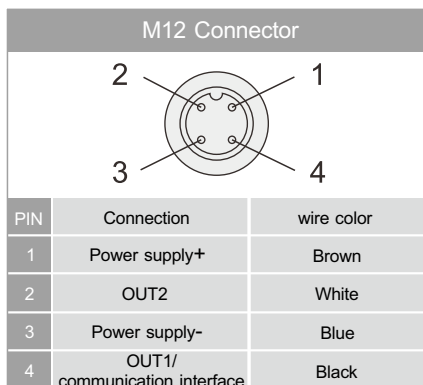

- R1 and R2 indicate the load of OUT1 and OUT2.
- To protect the sensor from abnormal condition, we strongly recommend to adopt FUSE 0.5A on the power supply circuit.
- This wire color only represents the property. The actual wire color depends on the connector purchased.

Note: The accuracy and efficiency can not be guaranteed if using NON-FineTek connector.

# ORDER INFORMATION

SIS1 0 0   -  MAD                  A

**⑦ ⑧ Certification**  
 00: N/A    7D: NEPSI-Ex tD

**⑨ Rod type**  
 A: Standard type  
 B: Extension type  
 C: Mini type (non-explosion-proof model only)  
 D: Rear install type (non-explosion-proof model only)

**⑬ ⑭ Output**  
 25: PNP    26: NPN

**⑮ Output function**  
 A: OUT1=NO, OUT2=NC (Default setting)  
 B: OUT1=NC, OUT2=NO  
 C: OUT1=NO, OUT2=NO  
 D: OUT1=NC, OUT2=NC

**⑯ Medium type**  
 A: Water-based(Dielectric constant  $\epsilon \geq 15$ )  
 B: Oils, greases, powders (Dielectric constant  $\epsilon \leq 15$ )  
 C: With low water content or viscous (Dielectric constant  $\epsilon \leq 15$ )  
 D: Powder media (Dielectric constant  $\epsilon \geq 1.5$ ), (only for Ex tD Explosion-proof)

**⑰ ⑱ Wetted material**  
 MB: SUS316    MC: SUS316L

**⑲ ⑳ ㉑ ㉒ ㉓ ㉔ Connection**  
 AAA517: G 1/2"  
 ABK582: M32\*P1.5 (only for rear install type)

**㉕ ㉖ Probe material**  
 13: PEEK  
 63: PEEK-1000 (only for Ex tD Explosion-proof)

**㉘ ㉙ ㉚ ㉛ Rod length**

Code	Length
0047	47mm(Standard or Mini type)
0072	72mm(Extension type)
0029	29mm(Rear install type)

# ACCESSORIES - THREAD CONNECTOR/ADAPTOR (OPTIONAL)

## Thread connector (While sensor welded aside tank wall) specification:

Connection specification	Weld opening	Exterior dimension	Technical parameters		
G 1/2"	φ45mm		Material	Order Code	
			SUS316	SISAM1P-MBA245S101	
			SUS316L	SISAM1P-MCA245S101	
	Application:		<ul style="list-style-type: none"> <li>Structural resistance to pressure 50Bar</li> <li>Reinforced structure of welding beads φ45</li> </ul>		
	φ45mm		Material	Order Code	
			SUS316	SISAM1P-MBA145S101	
			SUS316L	SISAM1P-MCA145S101	
	Application:		<ul style="list-style-type: none"> <li>Structural resistance to pressure 50Bar</li> <li>Reinforced structure of welding beads φ45</li> <li>With drain hole</li> </ul>		
	φ29mm		Material	Order Code	
			SUS316	SISAM1P-MBA429S101	
			SUS316L	SISAM1P-MCA429S101	
	Application:		<ul style="list-style-type: none"> <li>Structural resistance to pressure 50Bar</li> <li>For storage tank DN25~DN100</li> </ul>		
	φ29mm		Material	Order Code	
			SUS316	SISAM1P-MBA329S101	
			SUS316L	SISAM1P-MCA329S101	
	Application:		<ul style="list-style-type: none"> <li>Structural resistance to pressure 50Bar</li> <li>For storage tank DN25~DN100</li> <li>With drain hole</li> </ul>		
	φ30mm		Material	Order Code	
			SUS316	SISAM1P-MBA430S101	
SUS316L			SISAM1P-MCA430S101		
Application:		<ul style="list-style-type: none"> <li>Structural resistance to pressure 50Bar</li> <li>For storage tank</li> </ul>			
φ30mm		Material	Order Code		
		SUS316	SISAM1P-MBA330S101		
		SUS316L	SISAM1P-MCA330S301		
Application:		<ul style="list-style-type: none"> <li>Structural resistance to pressure 50Bar</li> <li>For storage tank</li> <li>With drain hole</li> </ul>			



### Thread adaptor (for small to large diameter installation) specifications

Female thread specification	Male thread specification	Exterior dimension	Technical parameters	
None	G 1/2"		Material	Order Code
			SUS316	SISAM1P-MBA500S101
			SUS316L	SISAM1P-MCA500S101
			Application: <ul style="list-style-type: none"> <li>The sealing plug is used to close up any hole on the device to prevent leakage.</li> <li>Locking torque 30~50Nm</li> </ul>	
G 1/2"	G 3/4"		Material	Order Code
			SUS316	SISAM1P-MBA600S201
			SUS316L	SISAM1P-MCA600S201
	Application: <ul style="list-style-type: none"> <li>Small to large diameter connector</li> <li>Thread installation for probe connector G 1/2" in G 3/4"</li> </ul>			
	3/4"NPT		Material	Order Code
			SUS316	SISAM1P-MBA600S301
SUS316L			SISAM1P-MCA600S301	
Application: <ul style="list-style-type: none"> <li>Small to large diameter connector</li> <li>Thread installation for probe connector G 1/2" in 3/4"NPT</li> </ul>				

#### Instructions for using the thread connector and adaptor

- For application related to food and environmental hygiene EHEDG or 3A standards, please comply with requirements stipulated in laws and regulations.
- The 3A certification specified here applies only to the sealed sensor equipped with PEEK probe.
- The surface should not be contaminated or damaged.
- Welding must be performed by authorized professionals.
- Do not install the sensor when it is cooling down during or after welding.
- The material of the welding rod must meet connector and tank (pipeline) standards.
- The welding power and degree of penetration must meet the tank (pipeline) wall thickness and requirements stipulated in laws and regulations.
- Welding should not cause any deformation to the thread connector, which may hinder installation.
- The seal of the thread connector should not be damaged by weld spatter or collision.
- For the welding operation, please refer to "SISB Welding Adapter / Thread Adaptor Operating Instructions".

### Installation of thread connector

1. Drill a hole in the tank/pipeline wall while in installation position based on the external diameter of the “thread connector” with a maximum tolerance of + 0.2mm.
  2. Perform dot welding with sufficient strength of 4-8 points in the junction between the tank/pipeline wall and the “thread connector”, with the same spacing as shown in Figure 1
  3. Weld the section between the two points as well as the opposite section. Finish the operation by section Based on Figure 2 & Figure 3. This is mainly to avoid welding stress and overheating, which may result in deformation of the “thread connector” and affect installation.
  4. After welding is completed, there should be enough time for the “thread connector” to cool down before installing the sensor.
  5. The screw thread and sealing surface should have no welding traces and damage.
  6. If the sealing surface of the “thread connector” is damaged, it can no longer be used. In this case, replace the item and repeat the welding process.
- ※ It is recommended that thread connector should be locked with bolt (don't lock too tight) before welding. After welding is completed, it can be removed after cooling to minimize welding deformation.

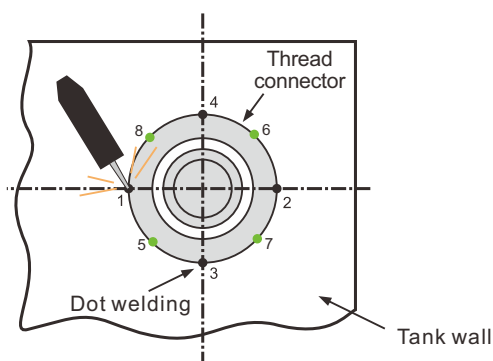

(Figure 1)

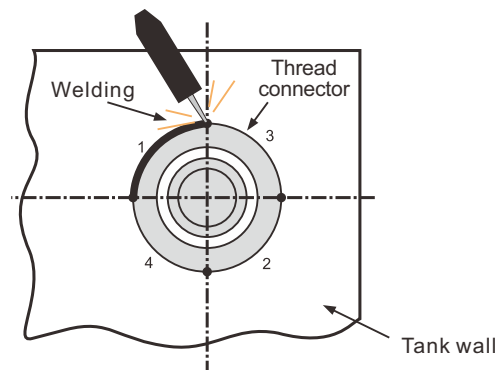

(Figure 2)

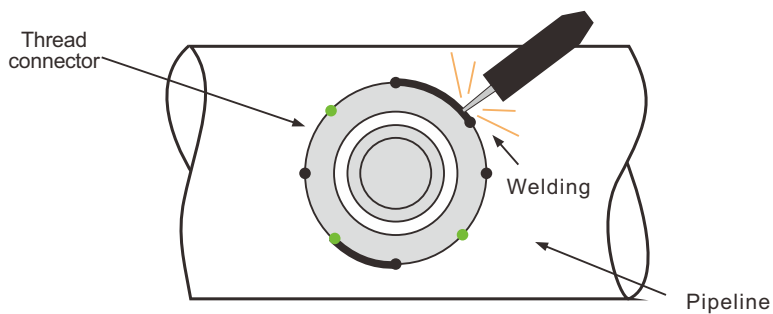

Pipeline welding(Figure 3)

# ACCESSORIES-ELECTRICAL CABLE CONNECTOR (OPTIONAL)

## M12 ELECTRICAL CABLE CONNECTOR

Order Code: PC312-1231415M01

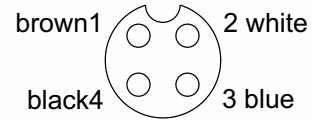
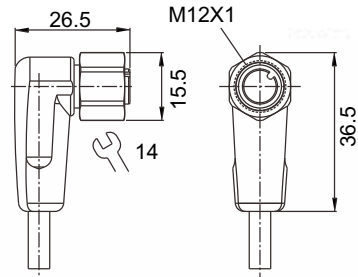

Order Code: PC312-2221410501

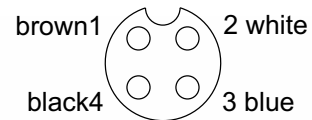
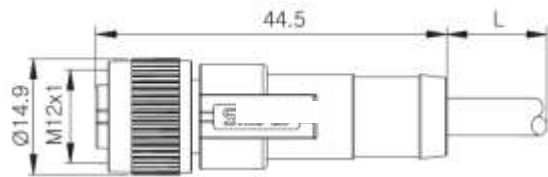

Order Code: PC312-1221415M01

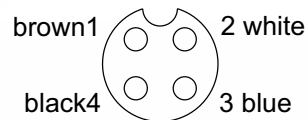
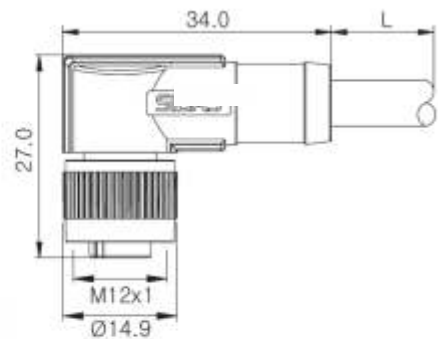

Oder Code: PC312-1232410501

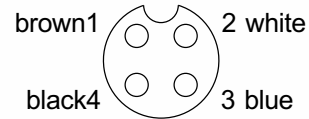
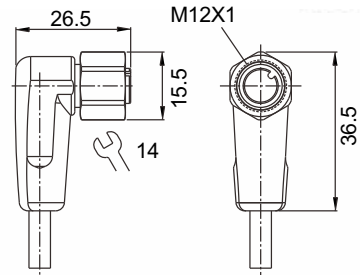

### M12 CONNECTOR SPECIFICATIONS

Order Code	Connector type	Cable length	Voltage rating	Current rating	Working temp.	Protection grade	Coating color	LED indicator
PC312-1231415M01 ※	Elbow 90°	5m	250Vac/300Vdc	Max.4A	-25°C~100°C	IP67 IP68 IP69K	Orange	NO
PC312-2221410501	Straight 180°	5m	250Vac	Max.4A	-25°C~80°C	IP67	Blue	NO
PC312-1221415M01	Elbow 90°	5m	250Vac	Max.4A	-25°C~80°C	IP67	Blue	NO
PC312-1272415M01	Elbow 90°	5m	10~30Vdc	Max.4A	-30°C~80°C	IP67	Black	YES
PC312-1232410501 ※	Elbow 90°	5m	10~36Vdc	Max.4A	-25°C~100°C	IP67 IP68 IP69K	Orange	YES

### NEW/OLD MODEL NO. COMPARISON TABLE

Old Model NO.	Order Code
26-0522-5M	PC312-1231415M01
26-0523-5M	PC312-2221410501
26-0524-5M	PC312-1221415M01
26-0525-5M	PC312-1272415M01
SCA-3371	PC312-1232410501

※ Use M12 cable type in dust explosion-proof environment which approved by NEPSI; ADOAH040VAS0005E04, ADOAH043VAS00005E04 (Order code; PC3121231415M011, PC312-1232410501)

# ACCESSORIES - PROGRAMMER BOX (OPTIONAL)

## PROGRAMMER BOX



Order Code	SISBA1X-0004
Exterior dimension(mm)	87X61X50(L XW XH)
Voltage rating	5Vdc(from USB)
Current consumption	Max.500mA
Input interface	Mini USB
Output interface	M12-5C A-Coded
Ambient temperature	-20°C~45°C(-4°F~113°F)
Protection grade	IP20

The programmer box function is to transmit sensor data to PC for reading and editing. Mainly supports calibration and parameter setting for SIS Intelligent Level Sensor.

- Reading current sensor parameter setting.
- Changing sensor parameter setting.
- Adjusting sensor sensitivity of current medium in real time.
- Calibrating current measuring value and do necessary adjustment promptly..

Note: The programmer box is only working while sensor data requiring transmit to PC for reading and editing, not a permanent connection automatic device.

## SYSTEM DIAGRAM

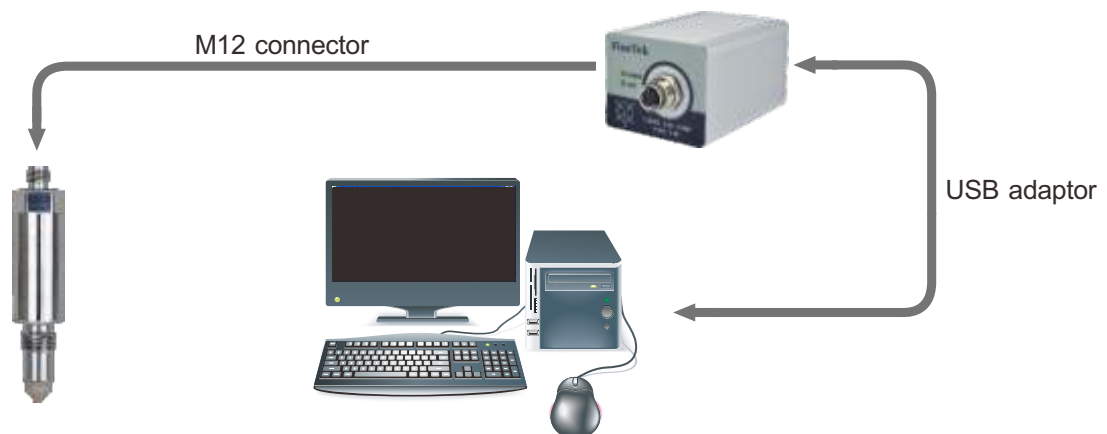

Using M12 connector to link SIS Impedance Spectroscopy Sensor” with programmer box.

Transmitting the sensor data by USB cable from programmer box to PC.

Note: The accuracy and efficiency can not be guaranteed if using NON-FineTek connector.