

FEATURES

- Economical version
- Fabricated from pipe
- Threaded process connection

APPLICATION

- HVAC, Air filters & utilities
- Tanks & vessels

Fabricated



STANDARD SPECIFICATIONS

Shank form	:	Straight
Head Material	:	AISI 316 SS
Well Material	:	AISI 316 SS
Instrument connection	:	1/2" NPT (F)
Well Tubes	:	Tube Ø10 x 1.5 mm THK
Lag extension	:	50 mm
Immersion length	:	300 mm
Tip thickness	:	5 mm
Process connection	:	1/2" NPT (M)
Head type	:	Hex
Head size	:	27 mm

DIMENSIONAL DRAWING

Straight Thermowell

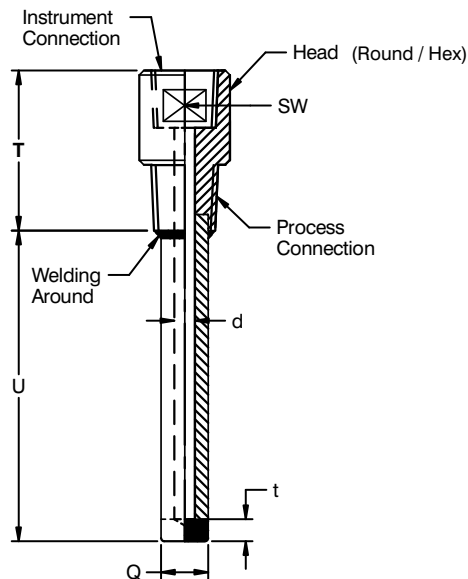

ORDERING CODES

1. SHANK FORM

S Straight

S

2. HEAD MATERIAL

MC AISI 304SS	ME AISI 310 SS
MF AISI 316 SS	MG AISI 316L SS
MI AISI 321 SS	M6 AISI 446 SS
MQ Inconel 600	MR Inconel 625
MS Inconel 800	MT Inconel 825
MO Hastelloy C-276	

MC

3. WELL MATERIAL

MC AISI 304SS	ME AISI 310 SS
MF AISI 316 SS	MG AISI 316L SS
MI AISI 321 SS	M6 AISI 446 SS
MQ Inconel 600	MR Inconel 625
MS Inconel 800	MT Inconel 825
MO Hastelloy C-276	

MC

4. INSTRUMENT CONNECTION

02N 1/4" NPT (F)	04N 1/2" NPT (F)
05N 3/4" NPT (F)	02B 1/4" BSP (F)
04B 1/2" BSP (F)	05B 3/4" BSP (F)
04M M20 x 1.5 mm (F)	

02N

5. PROCESS CONNECTION

14N 1/2" NPT (M)	15N 3/4" NPT (M)
16N 1" NPT (M)	17N 1.5" NPT (M)
18N 2" NPT (M)	14B 1/2" BSP (M)
15B 3/4" BSP (M)	16B 1" BSP (M)
17B 1.5" BSP (M)	18B 2" BSP (M)
14M M20 x 1.5 mm (M)	

14N

6. HEAD TYPE

H Hex
L Round with spanner slot

H

7. HEAD SIZE

XX Mention in 'mm'

XX

8. LAG EXTENSION ("T")

XXX 35 mm up to 250 mm

XXX

9. WELL (PIPE)

U3 Pipe 3/8" Sch 40
U4 Pipe 3/8" Sch 80
U5 Pipe 1/2" Sch 40
U6 Pipe 1/2" Sch 80
U7 Pipe 3/4" Sch 40
U8 Pipe 3/4" Sch 80
UA Pipe 1/4" Sch 40
UB Pipe 1/4" Sch 80
UC Pipe 1/2" Sch 160
UD Pipe 3/4" Sch 160

U3

9. WELL (TUBE) OR

U1 Tube Ø10 x 1.5 mm THK
UL Tube Ø12 x 2.5 mm THK
UM Tube Ø14 x 2.5 mm THK
UN Tube Ø12 x 1.0 mm THK
UO Tube Ø14 x 1.0 mm THK
UP Tube Ø16 x 2.0 mm THK

U1

10. IMMERSION LENGTH ("U")

XXXX 50 mm up to 1000 mm

XXXX

11. TIP THICKNESS ("t")

M 5 mm
N 6.35 mm (1/4")
O 10 mm

M

12. OTHER OPTIONS

XI Plug & chain in SS
XM Marking by engraving
TC Material test certificate 3.1
TD Dye penetration test
TM Material test certificate 2.2
TH Hydro test certificate

XM

Ordering Example : W101-S-MC-MC-02N-14N-H-XX-XXX-U3-U1-XXXX-M-XM

NOTES:

1. Other pipe/tube sizes, "U" lengths, connections are available. please contact factory for details.