

FEATURES

- Weld-in / Socket-weld design
- Solid bar-stock drilled

APPLICATION

- Oil & Gas applications
- Corrosive environments
- On-shore/Off-shore application
- Power & Utility

Bar-stock



STANDARD SPECIFICATIONS

Shank form	:	Tapered
Material	:	AISI 316 SS
Instrument connection	:	1/2" NPT (F)
Bore diameter	:	6.6 mm
Lag extension	:	50 mm
Root diameter	:	21.0 mm
Tip diameter	:	16.0 mm
Immersion length	:	300 mm
Step / Taper Length	:	100 mm
Tip thickness	:	5 mm
Process connection	:	Weld connection
Head type	:	Round
Head size	:	27 mm

DIMENSIONAL DRAWING

Weld-In / Stock-Weld Thermowell

Straight Thermowell

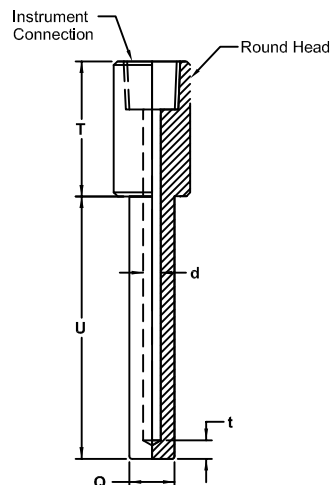

Step Thermowell

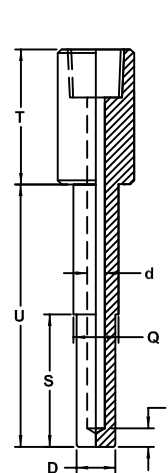

Taper Thermowell

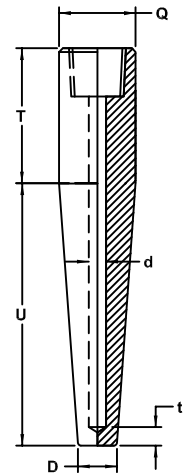

REFERENCE

ASME PTC 19.3TW:2010

ORDERING CODES

1. SHANK FORM

- S Straight
- E Stepped
- T Tapered

S

2. MATERIAL

- MB Carbon Steel / ASTM A105
- MC AISI 304SS
- ME AISI 310 SS
- MF AISI 316 SS
- MG AISI 316L SS
- MM Monel 400
- MN Monel K-500
- MO Hastelloy C-276
- MQ Inconel 600
- MR Inconel 625
- MS Inconel 800
- MT Inconel 825
- MV Titanium
- MY Alloy 20
- M6 AISI 446 SS
- MI AISI 321 SS

MB

3. INSTRUMENT CONNECTION

- 02N 1/4" NPT (F)
- 04N 1/2" NPT (F)
- 05N 3/4" NPT (F)
- 02B 1/4" BSP (F)
- 04B 1/2" BSP (F)
- 05B 3/4" BSP (F)
- 04M M20 x 1.5 mm (F)

02N

4. BORE DIAMETER ("d")

- N 6.35 mm (1/4")
- A 6.6 mm
- C 9.0 mm
- D 9.6 mm
- O 10 mm

A

5. LAG EXTENSION ("T")

- XXX 35 mm up to 250 mm

XXX

6. ROOT DIAMETER ("Q")

- XX.X Mention in 'mm'

XX.X

7. TIP DIAMETER ("D")

- XX.X Mention in 'mm'

XX.X

8. IMMERSION LENGTH ("U")

- XXXX 50 mm up to 1000 mm

XXXX

9. STEP / TAPER LENGTH ("S")

- XXX Mention in 'mm'

XXX

10. TIP THICKNESS ("t")

- M 5 mm
- N 6.35 mm (1/4")
- O 10 mm

M

11. HEAD TYPE

- R Round

R

12. HEAD SIZE

- XX Mention in 'mm'

5

13. OTHER OPTIONS

- XI Plug & chain in SS
- XL Marking by laser
- XM Marking by engraving
- TC Material test certificate 3.1
- TG IGC test
- TH Hydro test certificate
- TI IBR certification
- TM Material test certificate 2.2
- TN Tested to NACE standards
- TO Certification for Oxygen service
- TP Performance test certificate
- TQ Certification for Hydrogen service
- TW WFC as per PTC 19.3TW:2010

XM

Ordering Example : W203-S-MB-02N-A-XXX-XX.X-XX.X-XXXX-XXX-M-R-5-XM

NOTES:

1. Other connections are available through adaptors.